

# EVAPORATIVE AIR COOLER INSTRUCTION MANUAL

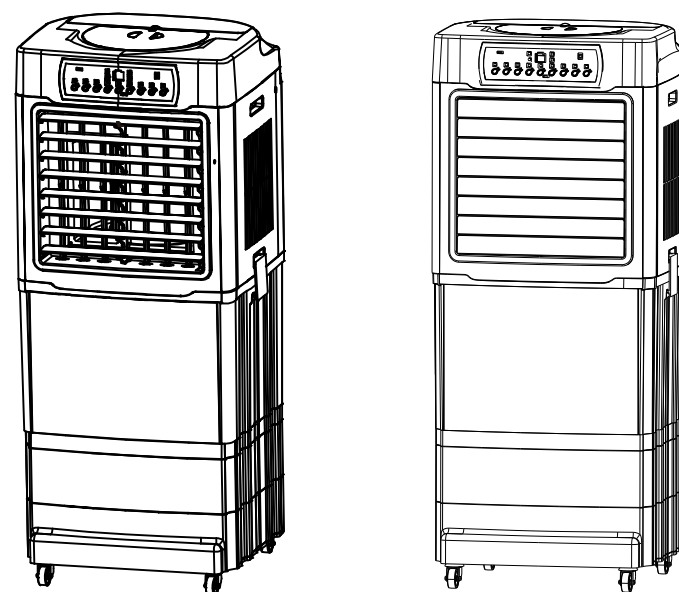

## LL-V9AL系列 LL-V9BL系列

LL-V9AL1     LL-V9AL2

LL-V9BL1     LL-V9BL2



Cooling



No polluting



Dustproof

Please carefully read this manual before attempting to use this evaporative air cooler and save it for future reference.

版本号	01	日期	20210402	图纸编号	
设计		修改人及日期			
审核		物料编码	114000211	图纸名称	说明书 通用//V9AL/ V9BL/遥控英文
备注					
共 页第 页			广东顺德锐铂汇电子科技有限公司		

### Warning

This appliance is not intended for use by persons (including children) with reduced physical, sensory, or mental capabilities, or lack of experience and knowledge, unless they have been given supervision or instruction concerning use of the appliance by a person responsible for their safety. Children should be supervised to ensure that they don't play with the appliance.

If there is a problem with this product, please contact the service point provided by the seller. If the problem cannot be solved by the service point, please contact our company directly.

Thank you for purchasing our air cooler. This manual is the universal version for various models of our household air coolers, so may the one you purchased is not in accordance with the one this manual introduces, but this doesn't affect your operation or use. Please read all the instructions in detail before first time use to ensure proper use of the machine. Besides please keep the manual for future reference.

## TABLE OF CONTENTS

Product Features.....	1
Construction Drawing .....	2
Spare Part List .....	3
Technical Parameters.....	3
Operation Instruction .....	3
Control Panel and Operation.....	4
Important Safeguards.....	4
Maintenance and Cleaning .....	5
Circuit Diagram .....	6
Trouble Shooting.....	6

## PRODUCT FEATURES

### ● Natural Cool

It cycles the water to blow cool air. It can lower the surrounding temperature and provide you a comfortable environment in hot summer.

### ● Air Clean

Unique water honeycomb washing function effectively removes the gases like formaldehyde, ammonia which comes from the paint, adhesives, and plywood of the new decorated houses. It also can filter the cigarette nicotine and freshen the air to care for your health.

### ● Ionizer

It releases negative ions to activate variety of enzymes to promote the human's metabolism and improve sleep quality. It also can be used for sterilization to freshen the air and care health.

### ● Detachable water tank, removable filtration mesh.

Separating water tank design, water-tight and easy to be cleaned, Clean by water, pour out the water, To prevent bacterial growth. Filter can be removed, clean it by Gentle clean economy and softy brush directly.

### ● 220W Energy saving, save power, High-efficiency, friendly environment

It used of advanced physical refrigeration technology, water storage capacity of large, long time, can be used for a long time. The entire input power is 220W, the power consumption is only 1/20 of the air conditioner.

### ● LED digital display & soft touch panel 120° wide range of air output

It's led digital display and soft touch panel, up and down adjust by hand freely, left and right 120° wide range of air output. 3 fan speeds: HIGH-MID-LOW, separate sleep mode, quiet and silent.

### ● Long distance remote control

6.5 meters remote control, 120° wide range receiver.

### ● Touch button, Beep prompt function

Touch button, Easy to operate. Beep prompt function sound good.

### ● Memory function

It can memorize the current working status and the memory is not cleaned until the power supply is off.

### ● Temperature detection and display

It can show the temp at any time.

### ● 24 hours Timer

1-24 hours timer setting, 24 hours will be closed automatically if no any operation.

### ● Water shortage Detection

When work with cool function, if water is not enough, "Bi-Bi" alarm sounds, the corresponding light flickers and then the water pump will stop working after 3 seconds if no water added in.

## CONSTRUCTION DRAWING

- |                           |  |                       |
|---------------------------|--|-----------------------|
| ① Horizontal blade        | ⑦ File cover                                 | ⑬ Wind wheel          |
| ② Vertical blade          | ⑧ Side cover                                 | ⑭ Fan base cover      |
| ③ Air outlet              | ⑨ Side protective net                        | ⑮ Back protective net |
| ④ Control panel           | ⑩ Upper side plate evaporator fixing groove  | ⑯ Back filter         |
| ⑤ Top cover               | ⑪ Bottom side plate evaporator fixing groove | ⑰ Side cover pull rod |
| ⑥ Top flip cover          | ⑫ Motor                                      | ⑱ Motor support       |
| ⑰ Vertical blade pull rod | ⑲ Hanger                                     | ⑳ Water pan           |
| ⑲ Horse                   | ⑳ Air duct top shell                         | ㉑ Water tank lid      |
| ㉑ Water tank lid support  | ㉒ Water pump cover                           | ㉒ Water pump          |
| ㉒ Water tank              | ㉓ Ornament strip                             | ㉓ Ornament board      |

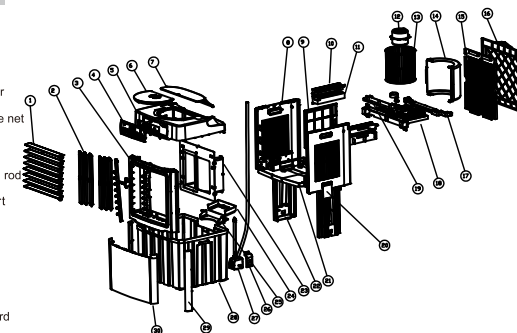

## Base Installation Guide

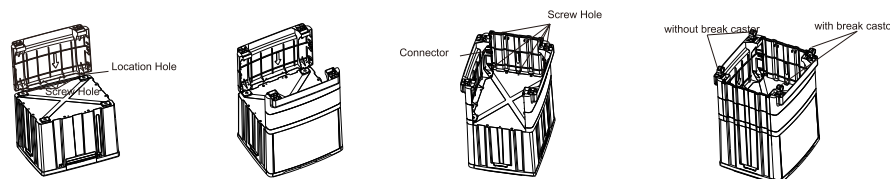

1. Installing the front & back decorative board according to the installation direction, then used the screws to fix the base.
2. Installing the left & right, front & back base decorative board according to the installation direction, and then using the screws to fix the base.
3. Casters Assembly: plug the casters into the bottom caster sockets, move cooler about to verify smooth rolling operation.

## SPARE PARTS

No.	Accessory Name	Quantity	Unit
1	Air cooler	1	set
2	Instruction manual	1	Pc
3	Power cord	1	Pc
4	Casters	4	Set
5	Remote controller	1	Pc

## TECHNICAL PARAMETERS

Model	LL-V9AL1	LL-V9AL2	LL-V9BL1	LL-V9BL2
Voltage	220V	220V	220V	220V
Power	220W	220W	220W	220W
Water tank capacity	45L	45L	45L	45L
N.W	17KGS	17KGS	17KGS	17KGS
G.W	20.4KGS	20.4KGS	20.4KGS	20.4KGS
Size	470x380x1130mm	470x380x1130mm	470x380x1130mm	470x380x1130mm
Packing size	520x440x1025mm	520x440x1025mm	520x440x1025mm	520x440x1025mm

**Remark:** Due to constant development of our production in regards to specification and design, we take reservation for changes without prior notice.

## OPERATION INSTRUCTION

- Pull the unit outwards from the carton and place it on the floor.
- Check if the spare parts are complete, same as the spare parts list.
- Place the unit on the floor. Take out the wheels to assemble.
 

**Note: Two casters with brake are for the two front holes and casters without brake are for the two front holes and casters without brake are for the two back holes at the bottom of the unit**
- Follow up the direction, then add water.(Show as fig 1)
 

**Note:**

  - Pay attention to the water level indicator to avoid overfilling.
  - Water level must be between the MIN and MAX line.
  - After some time operation dust and dirt may occur in water tank .It is recommended to change water and clean water tank frequently.
  - Water shortage alarm, when the water level is lower than "MIN" level, then the "Bi-Bi" alarm sound can be heard and the corresponding indicator light flickers, and after adding water to the normal water level, the light is off. then restart the cool function.
- Only use the unit with correct power required .Get the plug pin into power and a small "beep" sound can be heard and the unit is in standby state.
 

**Note:**

  - To protect against electric shock, do not remove plug by wet hand.
  - Unplug from outlet while moving the unit.
  - Insert the plug pin into the wall socket and make sure it is connected well

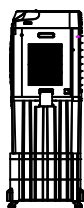

( fig 1 )

## CONTROL PANEL AND OPERATION

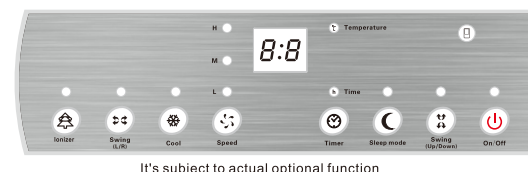

It's subject to actual optional function



The control function of the remote control is consistent with that of the buttons of corresponding models

- ON /OFF:** In the standby, press this button, then the digital display screen show temperature, and the wind wheel motor at low speed wind start.If shut down in the cool function,the water pump should be turn off approximately 15 minutes before the fan is turn off. This will allow the cooling pads to dry out and extend their life.
- SPEED:** Press this button to select desired fan speed, LOW- MID- HIGH- LOW.in turn. the corresponding speed indicator light will be displayed. the motor delays 5 seconds for the first start
- SLEEP MODE:** Sleep mode button is a valid key when power is, press this button,the corresponding indicator light is on and press this button again, then revert to work under the memorized speed.
- TIME:**It can be set between 1to 24 hours, with hourly incremental intervals,When the digital display 24 hours, press this button again to cancel and display '0' , after flicking 5 seconds automatically display the temperature.
- SWING:** When the fan is running, press the corresponding key to control the start and close of the vertical/horizontal blade swinging (first on, second off), the pendulum indicator light is on, the pendulum load is output, the upper, the lower, the left and the right automatically swing the wind.
- COOL:** press this button to control the switch of cool function (first on, second off)
- IONIZER:**the function start automatically when it is on. press this button to release negative ions into the air (first off, second on) the corresponding indicator light is on.
- TEMPERATURE DETECTION:** the temperature automatically display when the machine starts.

## IMPORTANT SAFEGUARDS

- Do NOT open and repair the unit by any unqualified person.
- Wet hands are not allowed to operate the machine, and cleaning and wiping of the connected-power machine is not allowed, to avoid damage caused by electric shock. If you do not use the unit for a long time, please unplug the power plug, drain the water tank, and put it in a dry and cool place.
- Do not insert any other objects into the grid of air vent (inlet or outlet) during operation. The machine is equipped with a high-speed rotating fan to prevent accidental injury or damage to the machine.
- Do not cover the appliance with paper, cardboard, plastic, metal foil, or any other flammable material. Otherwise, a fire may occur. Keep the appliance away from any hot sources.
- Do not use outdoors, indoors only. Avoid direct sunlight for a long time
- Water level must be between the MIN and MAX line.
- After filling with water, do not lean the unit and avoid moving it, which may cause water to overflow the sides of the tank and leak. If the unit needs to be moved a little, push on the side gently.
- Never put the unit side down especially with water inside, if it accidentally falls down, unplug the power immediately and don't restart until it's dry at least for 24 hours.

9. Do not place any objects on the top of the unit. Don't cover the unit window while using.
10. Keep the air vent (inlet or outlet) away from obstacles such as curtains, walls and so on.
11. Since this product can clean the air, the water in the water tank is easy to deteriorate and produce peculiar smell, please pay attention to change the water; Use this machine to humidify in winter, if the indoor temperature is below zero, it is better to use warm water to humidify.
12. Do not insert any other objects into the grid of air vent (inlet or outlet) during operation.
13. Don't use the unit in the damp environment like bathroom, swimming pool.
14. This appliance can be used by children aged from 8 years and above and persons without reduced physical, sensory or mental capabilities or lack of experience and knowledge if they have been given supervision or instruction concerning use of the appliance in a safe way and understand the hazards involved. Children shall not play with the appliance.
15. Cleaning and user maintenance shall not be made by children unless they are older than 8 and supervised.
16. Keep the appliance and its cord out of reach of children less than 8 years
17. If the supply cord is damaged, it must be replaced by its service agent or a similarly qualified person in order to avoid a hazard.
18. This appliance is intended to be used in household and similar applications such as:
  - staff kitchen areas in shops, offices and other working environments;
  - farm houses;
  - by clients in hotels, motels and other residential type environments;
  - bed and breakfast type environments.
19. Insert the power cord end into air cooler socket, make sure connect well. Must unplug the power cord pin from wall socket before moving the air cooler or adding water. Do not unplug the power cord end directly when the air cooler is working or moving the unit.

## MAINTENANCE AND CLEANING

**Note: After long time operation, the filtration mesh becomes clogged with dust and dirt, which will greatly affect the unit's performance. It is recommended to clean the filtration mesh every two week.**

### Cleaning the filtration mesh

1. Pull the plug
2. Loose screw, catch the filtration mesh handle and pull upwards.
3. Clean filtration mesh with mild detergent and soft brush.
4. Make sure filtration mesh is completely dry before installing.

### Cleaning the water tank

1. Remove the plug power.
2. Unlock the latches on both sides and lift off the cooler tap section and place it vertically on the floor.
3. Refill the water tank with clean water and drain it completely.
4. Pour out the water and make the water tank keep dry.

In order to keep greatly effect of cooling, it is recommend to clean the water tank every three months.

### Cleaning the body

Clean the body with a little mild detergent on a soft cloth.

### Note:

**Unplug from outlet before cleaning.**

**No water on the control panel and the top of the product..**

## CIRCUIT DIAGRAM

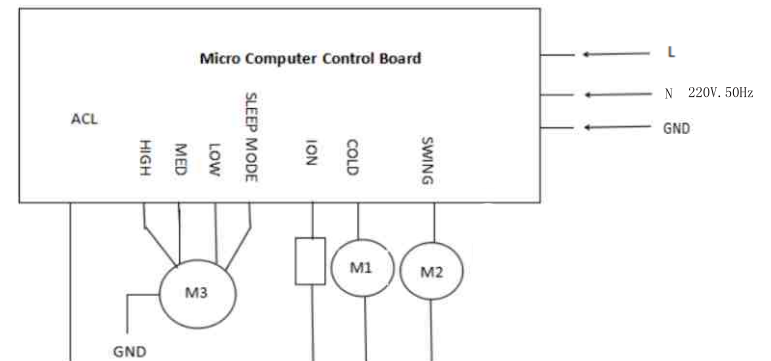

## TROUBLE SHOOTING

**Please contact our service center or qualified technician for further inspection if have follow problems:**

Problems	Possible reasons	Solutions
Not working	<ol style="list-style-type: none"> <li>1. The plug is not securely inserted into the socket or not connected well.</li> <li>2. The "ON/OFF" button is not pressed.</li> </ol>	<ol style="list-style-type: none"> <li>1. Insert the plug pin into the wall socket and make sure it is connected well</li> <li>2. Press "ON/OFF" button after plugged.</li> </ol>
Cool effect not good	<ol style="list-style-type: none"> <li>1. Not enough water in water tank</li> <li>2. Water pump is blocked</li> <li>3. Air vent is blocked by dust</li> </ol>	<ol style="list-style-type: none"> <li>1. Add water to ensure enough water for pumping</li> <li>2. Clean water tank and remove the impurities.</li> <li>3. Clean the dust or foreign objects from the air vent</li> </ol>
Error Code:E1	Problem in temperature sensor circuit	Please replace the probe

Notice:

1. The problem cannot be found in the list or it continues.
2. Foreign substances or water enter into air cooler, causing the air cooler cannot be run.



This marking indicates that this product should not be disposed with other household wastes throughout the EU. To prevent possible harm to the environment or human health from uncontrolled waste disposal, recycle it responsibly to promote the sustainable reuse of material resources. To return your used device, please use the return and collection systems or contact the retailer where the product was purchased. They can take this product for environmental safe recycling.