

EVAPORATIVE AIR COOLER INSTRUCTION MANUAL

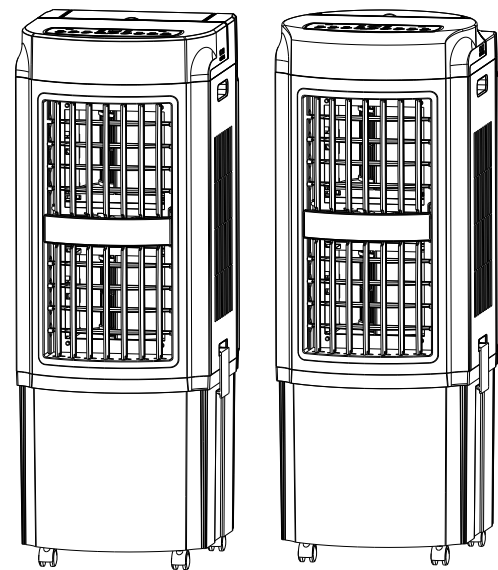

MODEL:LL-Q8A SERIES LL-Q8B SERIES

LL-Q8A□ LL-Q8A1□ LL-Q8A2□ LL-Q8A3□ LL-Q8A4□
LL-Q8A5□ LL-Q8A6□ LL-Q8A7□ LL-Q8A8□ LL-Q8A9□

LL-Q8B□ LL-Q8B1□ LL-Q8B2□ LL-Q8B3□ LL-Q8B4□
LL-Q8B5□ LL-Q8B6□ LL-Q8B7□ LL-Q8B8□ LL-Q8B9□

❄️ Colding 🌲 No polluting ✨ Dustproof

Please carefully read this manual before attempting to use this evaporative air cooler and save it for future reference.

版本号	01	日期	20210504	图纸编号	
设计		修改人及日期			
审核		物料编码	114000207	图纸名称	通用//LL-Q8A/LL-Q8B //英文
备注					
共 页第 页			广东顺德锐铂汇电子科技有限公司		

Table of Contents

Production Features.....	1
Construction Drawing.....	2
Spare parts List.....	2
Technical Parameters.....	3
Operation Instruction.....	3
Control Panel and Operation.....	4
Important Safeguards.....	4
Maintenance and Cleaning.....	5
Circuit Diagram	6
Trouble Shooting	6

Warning

This appliance is not intended for use by persons(including children) with reduced physical, sensory or mental capabilities, or lack of experience and knowledge.Unless they have been given supervision or instruction concerning used of the appliance by a person responsible for their safety. Children should be supervised to ensure that they don't play with the appliance. The company is not responsible for any consequences if any of the above action are in violation.

If there is a failure, please contact the guide on guarantee card, such as the maintenance station can not solve the problem can be directly contacted to our company.

Production Features

● Natural Cool

It cycles the water to blow cool air. It can lower the surrounding temperature and provide you a comfortable environment in hot summer.

● Air Clean, More fresher

Unique water honeycomb washing function effectively removes the gases like formaldehyde, ammonia which comes from the paint, adhesives and plywood of the new decorated houses. It also can filter the cigarette nicotine and freshen the air to care for your health.

● Ionizer

It releases negative ions to activate variety of enzymes to promote the human's metabolism and improve sleep quality. It also can be used for sterilization to freshen the air and care health.

● Separating water tank, detachable filtration mesh

Separating water tank design, water-tight and easy to be cleaned, Clean by water, pour out the water, To prevent bacterial growth. Filter can be removed, clean it by Gentle clean economy and softy brush directly.

● 100W Energy saving, save power, High-efficiency, friendly environment

It used of advanced physical refrigeration technology, water storage capacity of large, long time, can be used for a long time again and again. The entire input power is 80W, the power consumption is only 1/20 of the air conditioner. This product is environmentally home appliances, no fluoride pollution, are open doors and windows type cooling appliances, can be used as a partner of air conditioning products, the effect is better.

● LED digital display & soft touch panel 120 ° wide range of air output

It's led digital display and soft touch panel, up and down adjust by hand freely, left and right 120 ° wide range of air output. 3 fan speeds: HIGH-MID-LOW, separate sleep mode, quiet and silent.

● Long distance remote

6.5 meters remote control, 120° wide range receiver.

● Touch button, Beep prompt function

Touch button, Easy to operate. Beep prompt function sound good.

● Memory function

It can memorize the current working status and the memory is not cleaned until the power supply is off.

● Temperature detection and display

It can show the temp at any time.

● 24 hours Timer

1-24 hours timer setting, 24 hours will be closed automatically if no any operation.

● Water shortage Detection

When work with cool function , if water is not enough, "Bi-Bi" alarm sounds, the corresponding light flickers and then the water pump will stop working after 3 seconds if no water added in.

Construction Drawing

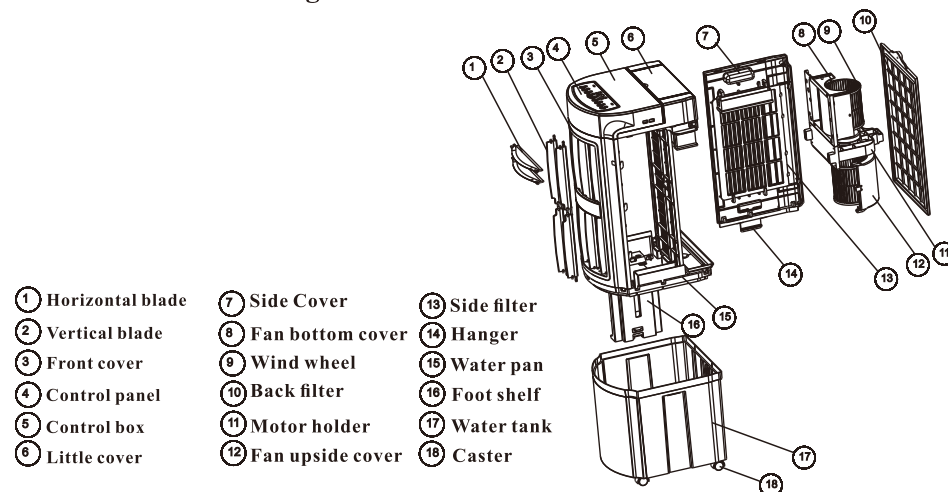

- | | | |
|--------------------|--------------------|---------------|
| ① Horizontal blade | ⑦ Side Cover | ⑬ Side filter |
| ② Vertical blade | ⑧ Fan bottom cover | ⑭ Hanger |
| ③ Front cover | ⑨ Wind wheel | ⑮ Water pan |
| ④ Control panel | ⑩ Back filter | ⑯ Foot shelf |
| ⑤ Control box | ⑪ Motor holder | ⑰ Water tank |
| ⑥ Little cover | ⑫ Fan upside cover | ⑱ Caster |

Spare parts list

No.	Accessory Name	Quantity	Unit
1	Air cooler	1	set
2	Remote controller	1	Pc
3	Instruction manual	1	Pc
4	Casters	4	Pcs
5	Power cord	1	Pc

Technical Parameters

Model No.	LL-Q8A1/LL-Q8B1	LL-Q8A/LL-Q8B
Voltage	220V	220V
Frequency	50Hz	50Hz
Power	100W	100W
Max Air Flow	2000m ³ /h	2000m ³ /h
Max Capacity	20L	30L
Net weight	11.4KGS	11.9KGS
Gross weight	12.7KGS	13.4KGS
Production size	350x380x870mm	350x380x970mm
Packing size	385x410x870mm	385x410x970mm

Remark: Due to constant development of our production in regards to specification and design, we take reservation for changes without prior notice.

OPERATION INSTRUCTION

- 1、 Pull the unit outwards from the carton and place it on the floor.
- 2、 Check if the spare parts are complete, same as the spare parts list.
- 3、 Place the unit on the floor. take out the wheels to assemble.

Note: Two casters with brake are for the two front holes and casters without brake are for the two back holes at the bottom of the unit.

- 4、 Follow up the direction, then add water.(Show as fig 1)

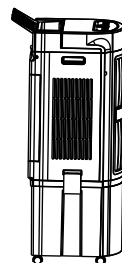

(fig 1)

Note:

Pay attention to the water level indicator to avoid overfilling.

- Water level must be between the MIN and MAX line.
 - With purifying air function, after some time operation, water in water tank may have smell. It is recommended to change water and clean water tank frequently.
 - Water shortage alarm, when the water level is lower than "MIN" level, then the "Bi-Bi" alarm sound can be heard and the corresponding indicator light flickers, and after adding water to the normal water level, the light is off. Then restart the cool function.
- 5.Only use the unit with correct power required .Get the plug pin into power and a small "beep" sound can be heard and the unit is in standby state.

Note:

- To protect against electric shock, do not remove plug by wet hand.
- Unplug from outlet while moving the unit.
- Insert the plug pin into the wall socket and make sure it is connected well

CONTROL PANEL AND OPERATION

- 1、 **ON/OFF:** In the standby, press this key, then the digital display screen show temperature, and the wind wheel motor at low speed wind start. If the shutdown in the cool function, the machine will delay 15 minutes to dry filter, after automatic shutdown. Press again the button to turn off.
- 2、 **SPEED:** Press this button to select desired fan speed, LOW- MID- HIGH- LOW. in turn. the corresponding speed indicator light will be displayed. the motor delays 5 seconds for the first start

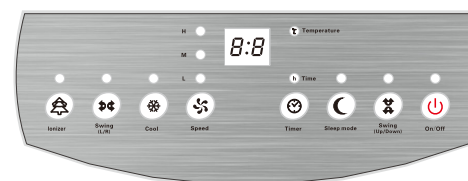

- 3、 **SLEEP MODE:** Sleep mode button is a valid key when power is, press this button, the corresponding indicator light is on and press this button again, then revert to work under the memorized speed.
- 4、 **SWING:**press this button to control the switch of the motor of Vertical wind blade(first on, second off) the corresponding indicator light is on, mean that load output.; Up and Down swing automatically.
- 5、 **COOL:** press this button to control the switch of cool function (first on, second off)
- 6、 **IONIZER:**the function start automatically when it is on. press this button to release negative ions into the air(first off, second on)the corresponding indicator light is on.
- 7、 **TEMPERATURE DETECTION:** the temperature automatically display when the machine starts.
- 8、 **TIME:** It can be set between 1 to 24 hours, with hourly incremental intervals. When the digital display 24 hours, press this button again to cancel and display "0", after flicking 5 seconds automatically display the temperature.

IMPORTANT SAFEGUARDED

- 1、 Do NOT open and repair the unit by any unqualified person.
- 2、 Wet hands are not allowed to operate the machine, and cleaning and wiping of the connected-power machine is not allowed, to avoid damage caused by electric shock. If you do not use the unit for a long time, please unplug the power plug, drain the water tank, and put it in a dry and cool place.
- 3、 Do not insert any other objects into the grid of air vent (inlet or outlet) during operation. The machine is equipped with a high-speed rotating fan to prevent accidental injury or damage to the machine.
- 4、 Do not cover the appliance with paper, cardboard, plastic, metal foil, or any other flammable material. Otherwise, a fire may occur. Keep the appliance away from any hot sources.
- 5、 Do not use outdoors, indoors only. Avoid direct sunlight for a long time
- 6、 Water level must be between the MIN and MAX line.
- 7、 After filling with water, do not lean the unit and avoid moving it, which may cause water to overflow the sides of the tank and leak. If the unit needs to be moved a little, push on the side gently.
- 8、 Never put the unit side down especially with water inside, if it accidentally falls down, unplug the power immediately and don't restart until it's dry at least for 24 hours.
- 9、 Do not place any objects on the top of the unit. Don't cover the unit window while using.
- 10、 Keep the air vent (inlet or outlet) away from obstacles such as curtains, walls and so on.

11. Since this product can clean the air, the water in the water tank is easy to deteriorate and produce peculiar smell, please pay attention to change the water; Use this machine to humidify in winter, if the indoor temperature is below zero, it is better to use warm water to humidify.
12. Do not insert any other objects into the grid of air vent (inlet or outlet) during operation.
13. Don't use the unit in the damp environment like bathroom, swimming pool.
14. This appliance can be used by children aged from 8 years and above and persons without reduced physical, sensory or mental capabilities or lack of experience and knowledge if they have been given supervision or instruction concerning use of the appliance in a safe way and understand the hazards involved. Children shall not play with the appliance.
15. Cleaning and user maintenance shall not be made by children unless they are older than 8 and supervised.
16. Keep the appliance and its cord out of reach of children less than 8 years
17. If the supply cord is damaged, it must be replaced by its service agent or a similarly qualified person in order to avoid a hazard.
18. This appliance is intended to be used in household and similar applications such as:
 - staff kitchen areas in shops, offices and other working environments;
 - farm houses;
 - by clients in hotels, motels and other residential type environments;
 - bed and breakfast type environments.
19. Insert the power cord end into air cooler socket, make sure connect well. Must unplug the power cord pin from wall socket before moving the air cooler or adding water. Do not unplug the power cord end directly when the air cooler is working or moving the unit.

Maintenance and Cleaning

Note: After long time operation, the filtration mesh becomes clogged with dust and dirt, which will greatly affect the unit's performance. It is recommended to clean the filtration mesh every two weeks.

Cleaning the filtration mesh

1. Pull the plug.
2. Loose screw, catch the filtration mesh handle and pull upwards.
3. Clean filtration mesh with mild detergent and soft brush.
4. Make sure filtration mesh is completely dry before installing.

Cleaning the water tank

1. Remove the plug power.
2. Open the hooks on both sides of the tank, pull out of the water tank.
3. Add water into the water tank and clean.
4. Pour out the water and make the water tank keep dry.

In order to keep greatly effect of cooling, it is recommend to clean the water tank every three months.

Cleaning the body

Clean the body with a little mild detergent on a soft cloth.

Note:

- Unplug from outlet before cleaning.
- No water on the control panel and the top of the product.

CIRCUIT DIAGRAM

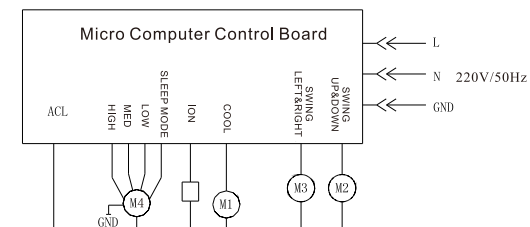

TROUBLE SHOOTING

If there is something wrong during operation, it may not be the unit's problem. You may check against the following list before sending for repair.

Problems	Possible reasons	Solutions
Not working	<ol style="list-style-type: none"> 1. The plug is not securely inserted into the socket or not connected well. 2. The "ON/OFF" button is not pressed. 	<ol style="list-style-type: none"> 1. Insert the plug pin into the wall socket and make sure it is connected well 2. Press "ON/OFF" button after plugged.
Cool effect not good	<ol style="list-style-type: none"> 1. Not enough water in water tank 2. Water pump is blocked 3. Air vent is blocked by dust 	<ol style="list-style-type: none"> 1. Add water to ensure enough water for pumping 2. Clean water tank and remove the impurities. 3. Clean the dust or foreign objects from the air vent
Error Code:E1	Problem in temperature sensor circuit	Please replace the probe

Notice:

Please contact our service center or qualified technician for further inspection if have follow problems:

1. The problem cannot be found in the list or it continues.
2. Foreign substances or water enter into air cooler, causing the air cooler cannot be run.



This marking indicates that this product should not be disposed with other household wastes throughout the EU. To prevent possible harm to the environment or human health from uncontrolled waste disposal, recycle it responsibly to promote the sustainable reuse of material resources. To return your used device, please use the return and collection systems or contact the retailer where the product was purchased. They can take this product for environmental safe recycling.